



Pneumatic atomizing nozzles, Flat fan, siphon principle, internal mixing Series 136.5 / 166.5



Particularly fine flat fan atomization with air or gas. Siphon principle. Internal mixing of fluids.

Applications:
Web dampening, cooling,
humidification of goods.

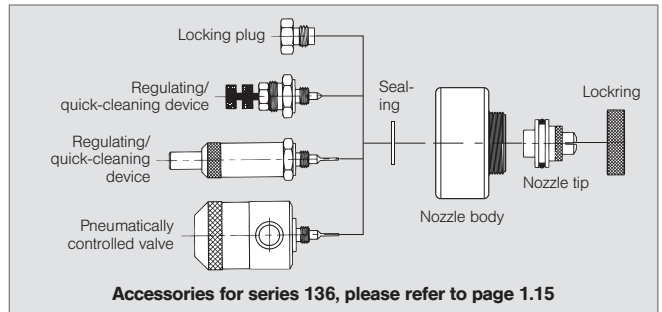
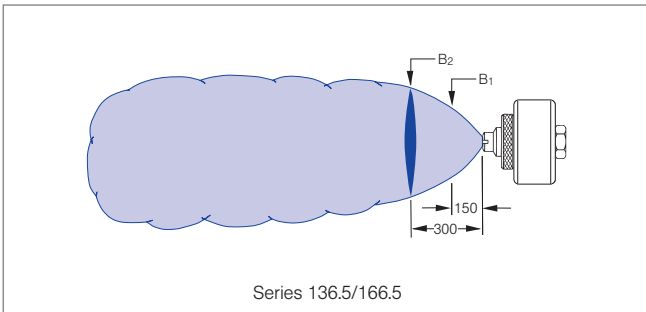
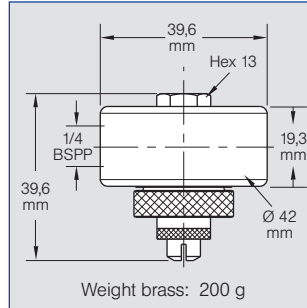

Spray angle	Ordering no..		E Ø [mm]	Air		V̇ Water [l/h]										Spray dimensions		
	Type	Mat. no.		p [bar]	V̇ _n [m ³ /h]	Water column [mm WS]			Aspiration height [mm WS]				p _{Air} [bar]	B ₁ [mm]	B ₂ [mm]			
						450	300	150	100	200	300	600				900		
60°	136. 523. xx. 14 166. 523. xx. 14	○ ○	0,70	1,50 2,00	1,60 2,50 3,00	3,90	3,50	3,20	2,70	2,50	2,30	1,50	1,10	0,70	250	500		
						3,60	3,30	3,00	2,70	2,70	2,60	2,30	1,90	1,50	190	390		
						3,00	2,70	2,50	2,30	2,30	2,10	1,80	2,00	180	350			
	136. 522. xx. 14 166. 522. xx. 14	○ ○	0,70	1,50 2,00	2,80 3,40	2,30 1,70	2,10	1,90	1,70	1,60	1,50	1,10	0,80	0,70	330	670		
							1,50	1,30	1,10	1,00	0,90	0,50	-	1,50	360	730		
							1,50	2,20	5,50	4,80	4,40	4,00	3,60	3,30	2,50	1,60	1,50	240
	136. 521. xx. 13 166. 521. xx. 13	○ ○	0,90	2,00 3,00 3,50	2,70 3,60 4,10	4,80 3,40 3,00	4,20	3,90	3,60	3,40	3,10	2,40	1,70	2,00	210	420		
							3,70	3,40	3,20	2,60	2,40	2,20	1,70	1,20	3,00	220	430	
							2,50	2,00	1,90	2,00	1,70	1,30	0,60	3,50	210	430		
	136. 519. xx. 13 166. 519. xx. 13	○ ○	1,00	1,50 2,00 3,00	1,90 2,30 3,60	6,50 5,60 4,40	5,90	5,60	4,90	3,90	3,60	3,60	3,10	2,40	2,00	160	320	
							4,40	4,00	3,60	3,90	3,70	3,70	3,00	2,40	3,00	180	350	
							3,60	3,80	3,80	3,40	3,30	3,30	2,60	2,10	3,50	180	350	
			4,00	4,00	3,70	3,50	3,30	2,90	2,80	2,80	2,20	1,80	4,00	180	350			

E = narrowest free cross section (water)

Example for ordering: Type 136. 523. xx. 14 + Material no. (xx) 16 = Ordering no. 136. 523. 16. 14