



Pneumatic atomizing nozzles, Full cone, pressure principle, internal mixing Series 136.2 / 166.2



Fine full cone atomization and fogging with air or gas. Especially wide spray angle of 60°. Pressure principle. Internal mixing of fluids.

Applications:
Humidification of air, cooling.



Series 136.2

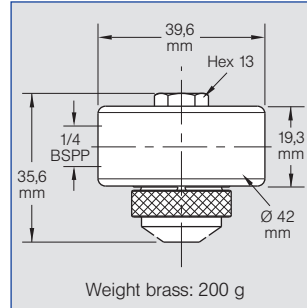

Weight brass: 200 g



Series 166.2 with magnetic valve
Weight brass: 350 g

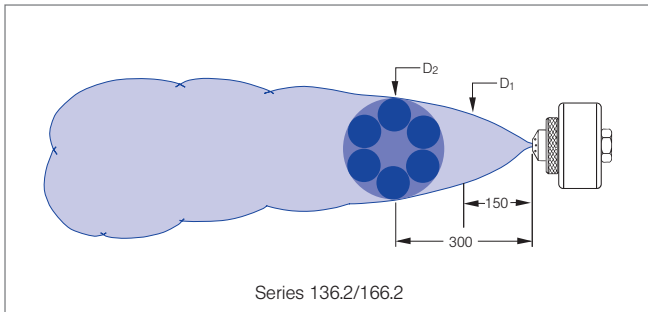

Series 136.2/166.2

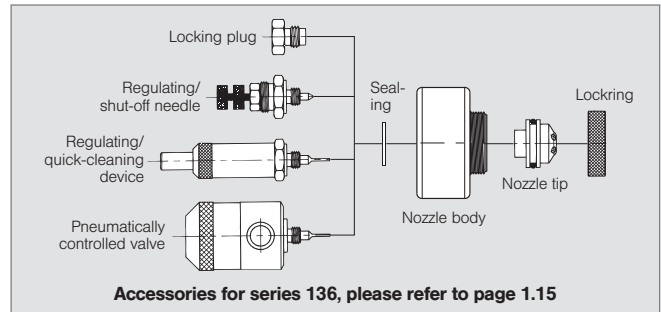

Accessories for series 136, please refer to page 1.15

Spray angle	Ordering no.		E Ø [mm]	Liquid pressure p [bar]												Spray dimensions				
	Type	Mat. no.		0,7			1,5			3,0			4,0			p Air [bar]	p Water [bar]	D1 [mm]	D2 [mm]	
				p Air [bar]	Ḃ Water [l/h]	Ḃn Air [m³/h]	p Air [bar]	Ḃ Water [l/h]	Ḃn Air [m³/h]	p Air [bar]	Ḃ Water [l/h]	Ḃn Air [m³/h]	p Air [bar]	Ḃ Water [l/h]	Ḃn Air [m³/h]					
60°	136. 206. xx. 15 166. 206. xx. 15	1.4305/303 SS Brass plated	0,50	-	-	-	1,40	6,10	1,50	2,90	7,40	2,60	4,10	7,50	3,50	1,50	1,50	200	300	
				-	-	-	1,50	5,60	1,60	3,20	6,40	2,90	4,50	6,20	3,90	2,30	2,00	200	330	
				-	-	-	1,70	4,70	1,80	3,30	5,90	3,00	4,80	5,10	4,20	3,20	3,00	200	330	
				-	-	-	1,80	4,20	1,90	3,40	5,60	3,10	5,20	3,50	4,70	4,10	4,00	200	330	
	136. 208. xx. 12 166. 208. xx. 12	1.4305/303 SS Brass plated	1,00	0,70	22,40	2,10	1,40	35,10	2,90	2,80	47,10	4,70	4,30	29,50	8,30	0,80	0,70	190	360	
				0,80	17,20	2,50	1,50	28,70	3,20	2,90	40,40	4,80	4,50	23,10	9,30	1,50	1,50	200	380	
				0,90	12,10	3,00	1,70	20,30	4,10	3,00	37,20	5,30	4,80	15,20	10,50	2,30	2,00	200	380	
				1,00	7,80	3,50	1,80	16,30	4,60	3,20	30,20	6,20	5,20	5,50	13,00	3,20	3,00	200	360	
				1,10	4,40	4,10	1,90	11,70	5,10	3,30	24,20	6,90	-	-	-	4,10	4,00	200	360	
				1,20	1,80	4,60	-	-	-	3,40	21,90	7,20	-	-	-	-	-	-	-	-
				-	-	-	-	-	-	3,60	14,70	8,30	-	-	-	-	-	-	-	-
				-	-	-	-	-	-	3,70	11,70	8,80	-	-	-	-	-	-	-	-
				-	-	-	-	-	-	3,80	7,30	9,60	-	-	-	-	-	-	-	-

E = narrowest free cross section (water)

Continued on next page.

Example: Type + Material no. (xx) = Ordering no.
for ordering 136. 206. xx. 15 + 16 = 136. 206. 16. 15