



Cluster head nozzles

Series 502 / 503



Fine full cone atomization with the aid of several hollow cones spraying into one another.

Applications:

Cooling of gaseous and solid material, desuperheating, chlorine precipitation, absorption as well as for improvement of chemical reaction by enlarging the contact area.

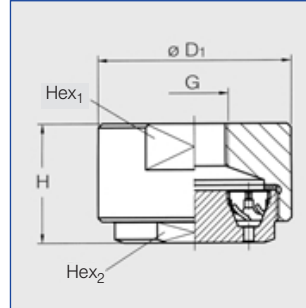

	Dimensions	
	1/2"	3/4"
Hex ₁	46	65
Hex ₂	38	55
H	25	46
D ₁	50	75
Weight (Brass)	250 g	870 g

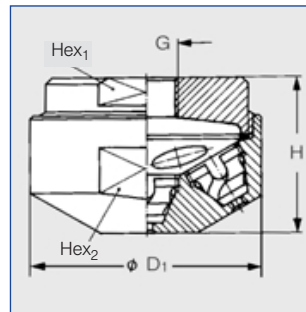
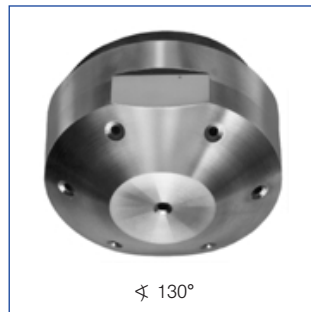

	Dimensions	
	1/2"	3/4"
Hex ₁	27	50
Hex ₂	36	55
H	28	53
D ₁	40	60
Weight (Brass)	150 g	410 g

Spray angle	Ordering no.		G	B ∅ [mm]	E ∅ [mm]	V̇ [l/min]						Spray diameter D at p = 2 bar	
	Type	Mat.-no.				p [bar]						Diagram	
						0,5	1,0	2,0	[US gal./min] at 40 psi	5,0	10,0	H = 1000 mm	H = 2000 mm
70°	502. 445	-	1/2"	1,00	0,50	-	-	1,25	0,39	1,98	2,80	400	400
	502. 985	○	3/4"	3,50	2,00	14,00	19,80	28,00	8,68	44,30	62,60	1200	1500
	503. 065	○	3/4"	5,00	2,00	22,10	31,80	45,00	13,96	71,10	100,60	1200	1800
130°	502. 448	○	1/2"	1,00	0,50	-	-	1,25	0,39	1,98	2,80	500	500
	502. 548	○	1/2"	1,80	0,50	-	1,58	2,24	0,69	3,54	5,01	700	700
	502. 748	○	3/4"	2,00	2,00	3,50	5,00	7,10	2,20	11,20	15,90	1100	1200
	502. 798	○	3/4"	2,50	2,00	4,60	6,70	9,50	2,95	15,00	21,20	1200	1300
	502. 838	○	3/4"	3,00	2,00	4,60	8,30	11,80	3,66	18,70	26,40	1400	1600
	502. 908	○	3/4"	4,00	2,00	8,80	12,70	18,00	5,58	28,40	40,20	1500	1800
	503. 028	○	3/4"	4,00	2,00	17,70	25,10	35,50	11,01	56,10	79,40	1600	1800
503. 118	○	3/4"	6,00	2,00	30,00	42,00	60,00	18,61	95,00	134,00	2000	3000	

B = bore diameter · E = narrowest free cross section

The folded page at the end of the catalogue will give you a survey on the various assembly possibilities. For complete assembly accessories, please refer to „Accessories“.

Example	Type	+	Material no.	=	Ordering no.
for ordering:	502. 445	+	30	=	502. 445. 30

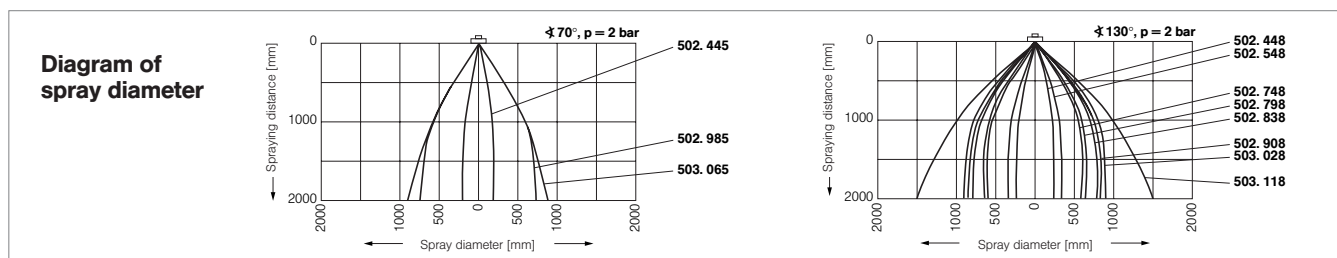

Conversion formula for the above series: $\dot{V}_2 = \dot{V}_1 \cdot \sqrt{\frac{P_2}{P_1}}$

