



Flat fan nozzles

Series 612



Compact design, suitable for narrow installation conditions. Stable spray angle. Uniform parabolic distribution of liquid.

Applications:

Cleaning installations, cooling headers spray pipes.

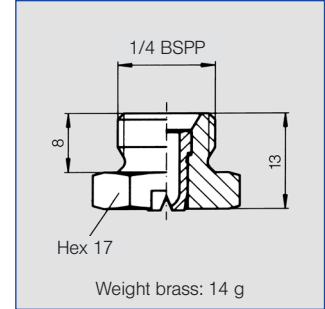

Spray angle	Ordering no.				A ∅ [mm]	E ∅ [mm]	V̇ [l/min]							Spray width B at p = 2 bar	
	Type	Material-no.					p [bar]								
		16	17	30											
		1.4305/303 SS	1.4571/316 SS	Brass			0,5	1,0	2,0	[US gal/min] at 40 psi	3,0	5,0	10,0	H= 250 mm	H= 500 mm
20°	612. 301	○	○	○	0,70	0,60	0,16*	0,23*	0,32	0,10	0,39	0,51	0,72	75	150
	612. 361	○	○	○	1,00	0,80	0,31*	0,44*	0,63	0,20	0,77	1,00	1,40	80	150
	612. 441	○	○	○	1,30	1,10	0,62*	0,88	1,25	0,39	1,53	1,98	2,80	80	155
	612. 481	○	○	○	1,50	1,20	0,80*	1,13	1,60	0,50	1,96	2,53	3,58	80	155
30°	612. 302	○	○	○	0,60	0,50	0,16*	0,23*	0,32	0,10	0,39	0,51	0,72	85	140
	612. 362	○	○	○	1,00	0,70	0,31*	0,44*	0,63	0,20	0,77	1,00	1,40	95	160
	612. 402	○	○	○	1,20	0,90	0,50*	0,71	1,00	0,31	1,23	1,58	2,24	105	190
	612. 482	○	○	○	1,50	1,10	0,80*	1,13	1,60	0,50	1,96	2,53	3,58	120	225
	612. 562	○	○	○	2,00	1,50	1,25	1,77	2,50	0,78	3,06	3,95	5,59	135	240
	612. 642	○	○	○	2,50	1,80	2,00	2,83	4,00	1,24	4,90	6,33	8,94	145	285
	612. 722	○	○	○	3,00	2,40	3,15	4,46	6,30	1,95	7,72	9,96	14,09	150	290
45°	612. 303	○	○	○	0,70	0,50	0,16*	0,23*	0,32	0,10	0,39	0,51	0,72	160	315
	612. 363	○	○	○	1,00	0,60	0,31*	0,44*	0,63	0,20	0,77	1,00	1,40	170	340
	612. 403	○	○	○	1,20	0,90	0,50*	0,71	1,00	0,31	1,23	1,58	2,24	175	345
	612. 483	○	○	○	1,50	1,10	0,80*	1,13	1,60	0,50	1,96	2,53	3,58	195	375
	612. 563	○	○	○	2,00	1,40	1,25	1,77	2,50	0,78	3,06	3,95	5,59	190	365
	612. 643	○	○	○	2,50	1,80	2,00	2,83	4,00	1,24	4,90	6,33	8,94	190	365
	612. 723	○	○	○	3,00	2,40	3,15	4,46	6,30	1,95	7,72	9,96	14,09	195	370
	612. 763	○	○	○	3,50	2,60	4,00	5,66	8,00	2,48	9,80	12,65	17,89	195	370
612. 803	○	○	○	4,00	3,00	5,00	7,07	10,00	3,10	12,25	15,81	22,36	195	370	
60°	612. 304	○	○	○	0,70	0,40	0,16*	0,23*	0,32	0,10	0,39	0,51	0,72	245	490
	612. 334	○	○	○	0,90	0,50	0,22*	0,32*	0,45	0,14	0,55	0,71	1,01	250	495
	612. 364	○	○	○	1,00	0,60	0,31*	0,44*	0,63	0,20	0,77	1,00	1,40	255	500
	612. 404	○	○	○	1,20	0,80	0,50*	0,71	1,00	0,31	1,23	1,58	2,24	260	510
	612. 444	○	○	○	1,35	0,90	0,62*	0,88	1,25	0,39	1,53	1,98	2,80	260	510
	612. 484	○	○	○	1,50	1,00	0,80*	1,13	1,60	0,50	1,96	2,53	3,58	270	525
	612. 514	○	○	○	1,65	1,10	0,95*	1,34	1,90	0,59	2,33	3,00	4,25	260	510
	612. 564	○	○	○	2,00	1,30	1,25	1,77	2,50	0,78	3,06	3,95	5,59	260	505
	612. 604	○	○	○	2,20	1,50	1,58	2,23	3,15	0,98	3,86	4,98	7,04	265	505
	612. 644	○	○	○	2,50	1,60	2,00	2,83	4,00	1,24	4,90	6,33	8,94	265	505
	612. 674	○	○	○	2,70	1,80	2,38	3,36	4,75	1,47	5,82	7,51	10,62	265	505
	612. 724	○	○	○	3,00	2,10	3,15	4,46	6,30	1,95	7,72	9,96	14,09	265	505
	612. 764	○	○	○	3,50	2,30	4,00	5,66	8,00	2,48	9,80	12,65	17,89	260	500
	612. 804	○	○	○	4,00	2,60	5,00	7,07	10,00	3,10	12,25	15,81	22,36	255	490
612. 884	○	-	○	5,00	3,40	8,00	11,31	16,00	4,96	19,60	25,30	35,78	255	490	

A = Equivalent bore diameter · E = narrowest free cross section
 *Differing spray pattern. Subject to technical modifications.

Continued on next page.

Conversion formula for the above series: $\dot{V}_2 = \dot{V}_1 * \sqrt{\frac{p_2}{p_1}}$

