

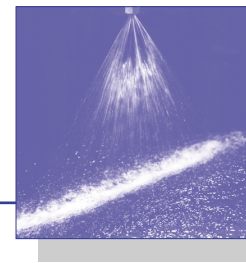

# Flat fan nozzles for retaining nut Series 652



**Assembly with retaining nut.  
Easy nozzle changing, simple  
jet alignment. Uniform, para-  
bolic distribution of liquid.  
Spray pipes equipped with  
these nozzles show an extre-  
mely uniform total liquid dis-  
tribution.**

Applications:

Spray cleaning, surface treat-  
ment, filter cleaning, belt clean-  
ing, lubricating, coating.

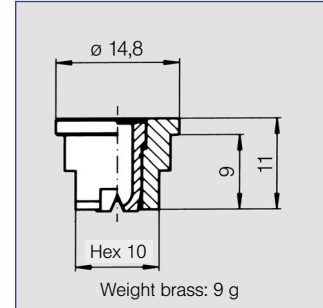

Spray angle	Ordering no.					A Ø [mm]	E Ø [mm]	ṽ [l/min]										Spray width B at p = 2 bar	
	Type	Material-no.						p [bar]										H =	
		16 1.4305/303 SS	17 1.4571/316 SS	30 Brass	5E PVDF			0,5	1,0	2,0	[US gal/ min] at 40 psi	3,0	5,0	10,0	250 mm	500 mm			
20°	652. 301	○	○	○	○	0,70	0,60	0,16*	0,23*	0,32	0,10	0,39	0,51	0,72	65	125			
	652. 361	○	○	○	○	1,00	0,80	0,31*	0,44*	0,63	0,20	0,77	1,00	1,40	65	125			
	652. 441	○	○	○	○	1,35	1,10	0,62*	0,88	1,25	0,39	1,53	1,98	2,80	65	125			
	652. 481	○	○	○	○	1,50	1,20	0,80*	1,13	1,60	0,50	1,96	2,53	3,58	65	125			
30°	652. 302	○	○	○	○	0,60	0,50	0,16*	0,23*	0,32	0,10	0,39	0,51	0,72	115	230			
	652. 362	○	○	○	○	1,00	0,70	0,31*	0,44*	0,63	0,20	0,77	1,00	1,40	115	230			
	652. 402	○	○	○	○	1,20	0,90	0,50*	0,71	1,00	0,31	1,23	1,58	2,24	115	230			
	652. 482	○	○	○	○	1,50	1,10	0,80*	1,13	1,60	0,50	1,96	2,53	3,58	115	230			
	652. 562	○	○	○	○	2,00	1,50	1,25	1,77	2,50	0,78	3,06	3,95	5,59	115	230			
	652. 642	○	○	○	-	2,50	1,80	2,00	2,83	4,00	1,24	4,90	6,33	8,94	120	230			
	652. 722	○	○	○	-	3,00	2,40	3,15	4,46	6,30	1,95	7,72	9,96	14,09	120	235			
	652. 762	○	○	○	-	3,50	2,70	4,00	5,66	8,00	2,48	9,80	12,65	17,89	120	235			
652. 802	○	○	○	-	4,00	3,10	5,00	7,07	10,00	3,10	12,25	15,81	22,36	120	240				
45°	652. 303	○	○	○	-	0,70	0,50	0,16*	0,23*	0,32	0,10	0,39	0,51	0,72	180	340			
	652. 363	○	○	○	-	1,00	0,60	0,31*	0,44*	0,63	0,20	0,77	1,00	1,40	185	340			
	652. 403	○	○	○	-	1,20	0,90	0,50*	0,71	1,00	0,31	1,23	1,58	2,24	185	340			
	652. 483	○	○	○	-	1,50	1,10	0,80*	1,13	1,60	0,50	1,96	2,53	3,58	185	340			
	652. 563	○	○	○	-	2,00	1,40	1,25	1,77	2,50	0,78	3,06	3,95	5,59	185	340			
	652. 643	○	○	○	-	2,50	1,80	2,00	2,83	4,00	1,24	4,90	6,33	8,94	185	345			
	652. 723	○	○	○	-	3,00	2,40	3,15	4,46	6,30	1,95	7,72	9,96	14,09	190	355			
	652. 763	○	○	○	-	3,50	2,60	4,00	5,66	8,00	2,48	9,80	12,65	17,89	190	355			
652. 803	○	○	○	-	4,00	3,00	5,00	7,07	10,00	3,10	12,25	15,81	22,36	195	360				
60°	652. 304	○	○	○	○	0,70	0,40	0,16*	0,23*	0,32	0,10	0,39	0,51	0,72	275	525			
	652. 334	○	○	○	○	0,90	0,50	0,22*	0,32*	0,45	0,14	0,55	0,71	1,01	275	525			
	652. 364	○	○	○	○	1,00	0,60	0,31*	0,44*	0,63	0,20	0,77	1,00	1,40	275	525			
	652. 404	○	○	○	○	1,20	0,80	0,50*	0,71	1,00	0,31	1,23	1,58	2,24	275	525			
	652. 444	○	○	○	○	1,35	0,90	0,62*	0,88	1,25	0,39	1,53	1,98	2,80	280	530			
	652. 484	○	○	○	○	1,50	1,00	0,80*	1,13	1,60	0,50	1,96	2,53	3,58	280	530			
	652. 514	○	○	○	○	1,65	1,10	0,95*	1,34	1,90	0,59	2,33	3,00	4,25	280	530			
	652. 564	○	○	○	○	2,00	1,30	1,25	1,77	2,50	0,78	3,06	3,95	5,59	280	525			
	652. 604	○	○	○	○	2,20	1,50	1,58	2,23	3,15	0,98	3,86	4,98	7,04	280	520			
	652. 644	○	○	○	○	2,50	1,60	2,00	2,83	4,00	1,24	4,90	6,33	8,94	275	520			
	652. 674	○	○	○	-	2,70	1,80	2,38	3,36	4,75	1,47	5,82	7,51	10,62	275	520			
	652. 724	○	○	○	○	3,00	2,10	3,15	4,46	6,30	1,95	7,72	9,96	14,09	275	520			
	652. 764	○	○	○	-	3,50	2,30	4,00	5,66	8,00	2,48	9,80	12,65	17,89	270	515			
	652. 804	○	-	-	○	4,00	2,60	5,00	7,07	10,00	3,10	12,25	15,81	22,36	270	510			
652. 844	○	-	-	○	4,50	3,00	6,25	8,84	12,50	3,88	15,31	19,76	27,95	270	510				
652. 884	○	-	○	-	5,00	3,40	8,00	11,31	16,00	4,96	19,60	25,30	35,78	270	505				

A = Equivalent bore diameter · E = narrowest free cross section · \*Differing spray pattern.

Continued on next page.

Conversion formula for the above series:  $\dot{V}_2 = \dot{V}_1 \cdot \sqrt{\frac{P_2}{P_1}}$

