



High pressure flat fan nozzles

Series 602 / 608 / 652



Sharp uniform flat fan with an extremely narrow jet depth.

Applications:
High pressure cleaners, steam jet cleaners

Materials:

Nozzle body: stainless steel
1.4305/303 SS

Insert: hardened stainless steel
1.4034 S

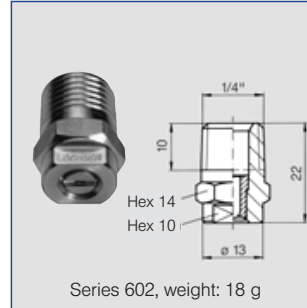
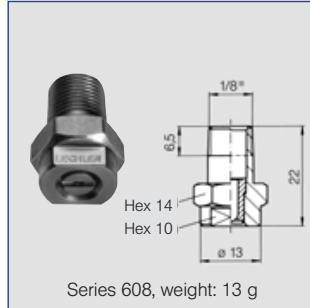

[US gal/min.] at 40 psi	Nozzle-Code			Flow rate code				A Ø [mm]	\dot{V} [l/min] (Tolerance ± 2%)						
	Connection			Spray angle					p [bar]						
	1/8"	1/4"	nut	↘15°	↘30°	↘45°	↘60°		40	60	80	100	120	150	200
02	608	602	652	361	362	363	364	1,00	2,86	3,50	4,04	4,52	4,95	5,53	6,39
025	608	602	652	381	382	383	384	1,10	3,54	4,33	5,00	5,59	6,12	6,85	7,91
03	608	602	652	401	402	403	404	1,18	4,31	5,28	6,10	6,82	7,47	8,35	9,64
034	608	602	652	411	412	413	414	1,30	4,95	6,06	7,00	7,83	8,57	9,59	11,07
04	608	602	652	451	452	453	454	1,35	5,80	7,10	8,20	9,17	10,04	11,23	12,97
045	608	602	652	471	472	473	474	1,40	6,51	7,97	9,20	10,29	11,27	12,60	14,55
05	608	602	652	481	482	483	484	1,55	7,29	8,92	10,30	11,52	12,62	14,11	16,29
055	608	602	652	501	502	503	504	1,60	7,96	9,74	11,25	12,58	13,78	15,41	17,79
06	608	602	652	521	522	523	524	1,72	8,70	10,66	12,31	13,76	15,07	16,85	19,46
065	608	602	652	531	532	533	534	1,75	9,38	11,49	13,26	14,83	16,25	18,16	20,97
07	608	602	652	541	542	543	544	1,80	10,06	12,32	14,22	15,90	17,42	19,47	22,49
075	608	602	652	551	552	553	554	1,90	10,75	13,16	15,20	16,99	18,62	20,81	24,04
08	608	602	652	571	572	573	574	2,05	11,48	14,06	16,23	18,15	19,88	22,23	25,67
09	608	602	652	591	592	593	594	2,10	13,01	15,93	18,40	20,57	22,53	25,19	29,09
10	608	602	652	601	602	603	604	2,30	14,43	17,76	20,40	22,81	24,99	27,94	32,26
125	-	602	652	641	642	643	644	2,50	17,82	21,82	25,20	28,17	30,86	34,51	39,85
15	-	602	652	671	672	673	674	2,70	21,35	26,15	30,20	33,76	36,98	41,35	47,74
175	-	602	652	701	702	703	704	3,00	25,03	30,66	35,40	39,58	43,36	48,47	55,97
20	-	602	652	-	-	723	724	3,05	28,85	35,33	40,80	45,62	49,97	55,87	64,52
30	-	602	652	-	-	793	-	3,90	42,43	51,96	60,00	67,08	73,48	82,16	94,88

A = Equivalent bore diameter

Connection Code	Connection	p _{max} [bar]
A3.00	BSPT	ca. 350
A3.07	NPT	ca. 350
A3.29	Lock nut	ca. 200

Example for ordering: Nozzle code + Flow rate code + Connection code = Ordering no.
602 + 361 + A3.07 = 602.361.A3.07
(Flat fan; 15°; 4,52 l/min. at 100 bar; 1/4" NPT)

Conversion formula for the above series: $\dot{V}_2 = \dot{V}_1 * \sqrt{\frac{p_2}{p_1}}$

