

For series	Ordering no.				Code	Screw (Material)	Pipe ø	D ø [mm]	Opening pressure [bar]	Closing pressure [bar]	Dimensions [mm]						Weight	
	Type	Material-no.									H <sub>1</sub>	H <sub>2</sub>	B <sub>R</sub> ø	B <sub>1</sub>	B <sub>2</sub>	B <sub>3</sub>		
		51	53	5E														56
302 Bayonet 422 Bayonet / 2TR 468/652 / 679 / 684	090. 003	○	○	○	-	KA	1.4305	1/2"	20-22,0	-	-	49,5	16,5	6,2	21,2	23,8	18,5	22g
	090. 013	○	○	○	-	KA	1.4305	3/4"	25-27,5	-	-	52,5	17,5	7,8	24,5	26,5	22,0	26g
	090. 023	○	○	○	-	KA	1.4305	1"	32-34,5	-	-	57,0	21,0	10,8	30,0	31,0	22,0	32g
302 Bayonet 422 Bayonet 2TR / 468 / 652 / 679 / 684	065. 272	-	-	-	○	KH	1.4305	1/2"	20-22,0	0,8	0,6	59	84	6,0				48g
	065. 272	-	-	-	○	KL	1.4305	3/4"	25-27,5	0,8	0,6	66	90	9,6				53g

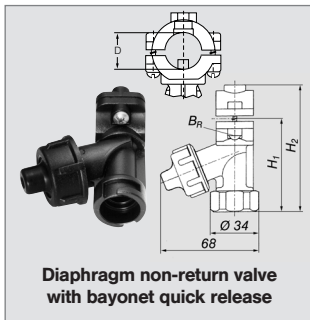

For series	Ordering no.	Material	Dimensions [mm]	
			L	R
302 Bayonet 422 Bayonet 2TR / 468 / 652 / 679 / 684	095. 016. 50. 08. 05	PVC	25	16
	095. 016. 53. 08. 05	PP	25	16

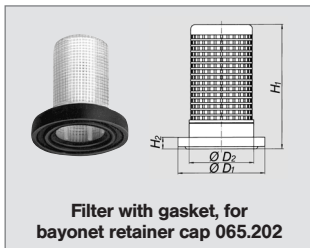
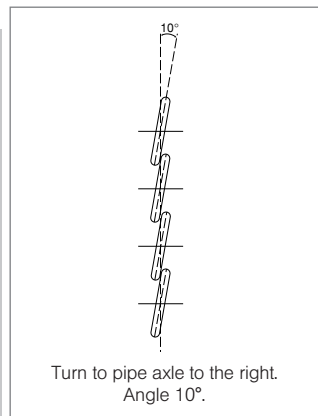
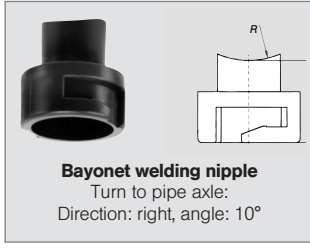

For nozzle size	Ordering no.		Mesh width [mm]	Colour	Dimensions [mm]				Weight
	Type	Mat-no			H <sub>1</sub>	H <sub>2</sub>	D <sub>1</sub>	D <sub>2</sub>	
		7J Santoprene							
xxx.32x-xxx.44x	065. 268	○	0,25	rot	21,5	2,5	18,0	11,0	2 g
xxx.48x-xxx.56x	065. 269	○	0,65	gelb	21,5	2,5	18,0	11,0	2 g

Example for ordering: Type + Material no. + Code = Ordering no.  
090. 003 + 51 + KA = 090. 003. 51. KA

