

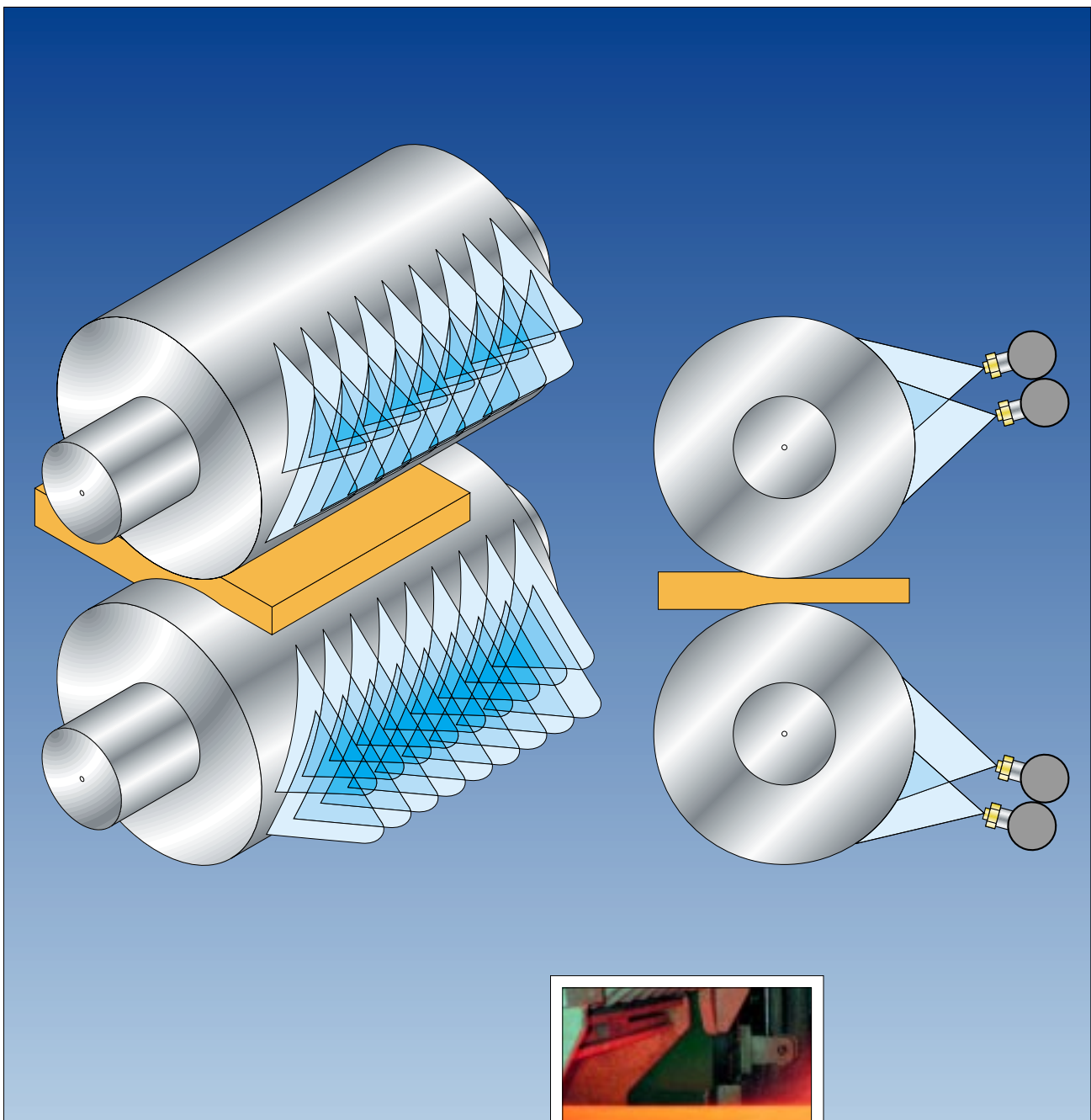

Precisions Nozzles and Systems for Roll Cooling and Lubrication in Rolling Mills

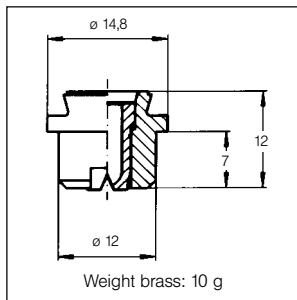

Flat Fan Dovetail Nozzles Series 660



Spray width [B] at p=3 bar

	H 250 mm	H 500 mm
660.301 - 331	70	125
660.361 - 761	90	175
660.801 - 881	100	200
660.302-332	110	210
660.362-402	135	260
660.442-882	150	300
660.303-333	175	350
660.363-403	200	400
660.443-923	220	440
660.304-334	250	470
660.364-404	315	600
660.444-924	330	630



Ordering no.				Mat. no.			E Ø [mm]	V̇ [l/min]							
Type				16	17	30		p [bar]							
20°	30°	45°	60°	303 SS	316 SS	Brass		40* psi							
660.301	660.302	660.303	660.304	○	-	○	0,4-0,6	0,16	0,23	0,32	0,10	0,39	0,50	0,59	0,71
660.331	660.332	660.333	660.334	○	-	○	0,5-0,7	0,22	0,32	0,45	0,14	0,55	0,71	0,84	1,00
660.361	660.362	660.363	660.364	○	○	○	0,6-0,8	0,31	0,44	0,63	0,20	0,77	0,99	1,17	1,40
660.401	660.402	660.403	660.404	○	○	○	0,8-1,0	0,50	0,70	1,00	0,31	1,22	1,58	1,87	2,23
660.441	660.442	660.443	660.444	○	○	○	0,9-1,1	0,62	0,88	1,25	0,39	1,53	1,97	2,33	2,79
660.481	660.482	660.483	660.484	○	○	○	1,0-1,2	0,80	1,13	1,60	0,50	1,96	2,53	2,99	3,57
660.511	660.512	660.513	660.514	○	○	○	1,1-1,4	0,95	1,34	1,90	0,59	2,32	3,00	3,55	4,24
660.561	660.562	660.563	660.564	○	○	○	1,3-1,5	1,25	1,76	2,50	0,78	3,06	3,95	4,67	5,59
660.601	660.602	660.603	660.604	○	○	○	1,5-1,7	1,57	2,22	3,15	0,98	3,85	4,98	5,89	7,04
660.641	660.642	660.643	660.644	○	○	○	1,6-1,9	2,00	2,82	4,00	1,24	4,89	6,32	7,48	8,94
660.671	660.672	660.673	660.674	○	○	○	1,8-2,2	2,37	3,35	4,75	1,47	5,81	7,51	8,88	10,62
660.721	660.722	660.723	660.724	○	○	○	2,1-2,5	3,15	4,45	6,30	1,95	7,71	9,96	11,78	14,08
660.761	660.762	660.763	660.764	○	○	○	2,3-2,8	4,00	5,65	8,00	2,48	9,79	12,64	14,96	17,88
660.801	660.802	660.803	660.804	○	○	○	2,6-3,2	5,00	7,07	10,00	3,10	12,24	15,81	18,70	22,36
660.841	660.842	660.843	660.844	○	○	○	3,0-3,6	6,25	8,83	12,50	3,88	15,30	19,76	23,38	27,95
660.881	660.882	660.883	660.884	○	○	○	3,4-4,0	8,00	11,31	16,00	4,96	19,53	25,29	29,93	35,77
-	-	660.923	660.924	○	○	○	4,1-4,4	10,00	14,14	20,00	6,21	24,49	31,62	37,42	44,72

E = Narrowest free cross section. * US gal/min.

Subject to technical modifications.

Accessories

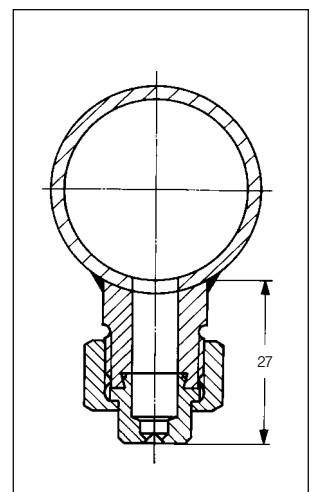
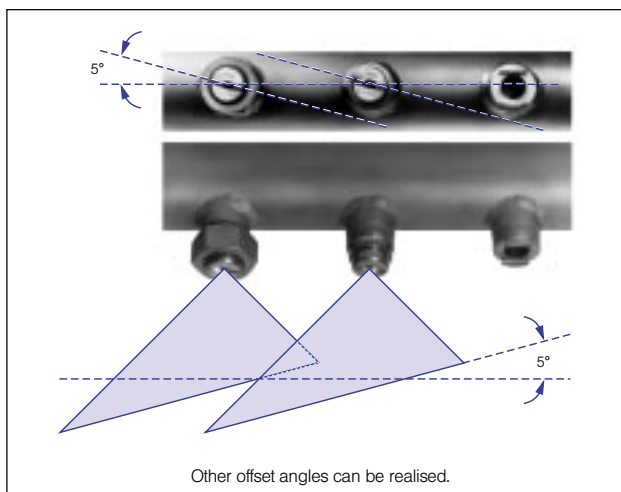
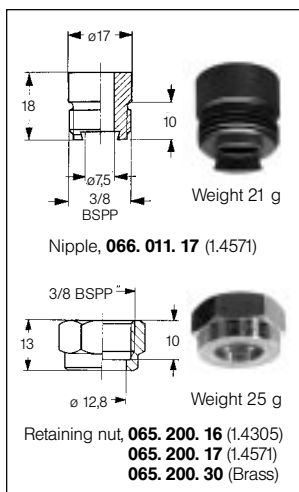

Flat Fan Dovetail Nozzles Series 664/665

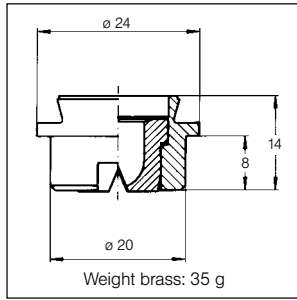

Spray width [B] at p=3 bar

	H 250 mm	H 500 mm
664.721 - 664.921	100	200
664.961 - 665.121	115	210
664.722 - 664.962	150	300
665.042 - 665.202	160	310
664.723 - 664.963	220	440
664.983 - 665.123	250	490
664.724 - 664.964	330	630
665.044 - 665.124	340	640



Ordering no.				Mat. no.			E Ø [mm]	V̇ [l/min]							
Type				16	17	30		p [bar]							
20°	30°	45°	60°	303 SS	316 SS	Brass		0,5	1,0	2,0	40* psi	3,0	5,0	7,0	10,0
664.721	664.722	664.723	664.724	○	○	○	2,1-2,5	3,15	4,45	6,30	1,95	7,72	9,96	11,79	14,09
664.761	664.762	664.763	664.764	○	○	○	2,3-2,8	4,00	5,66	8,00	2,48	9,80	12,65	14,97	17,89
664.801	664.802	664.803	664.804	○	○	○	2,6-3,2	5,00	7,07	10,00	3,10	12,25	15,81	18,71	22,36
664.841	664.842	664.843	664.844	○	○	○	3,0-3,6	6,25	8,84	12,50	3,88	15,31	19,76	23,39	27,95
664.881	664.882	664.883	664.884	○	○	○	3,4-4,0	8,00	11,31	16,00	4,96	19,60	25,30	29,93	35,78
664.921	664.922	664.923	664.924	○	○	○	4,1-4,4	10,00	14,14	20,00	6,20	24,49	31,62	37,42	44,72
664.961	664.962	664.963	664.964	○	○	○	4,2-5,3	12,50	17,68	25,00	7,75	30,62	39,53	46,77	55,90
-	-	664.983	-	○	○	○	4,7	14,00	19,80	28,00	8,68	34,29	44,27	52,38	62,61
-	-	665.013	-	○	○	○	5,2	16,75	23,69	33,50	10,40	41,03	52,97	62,67	74,91
665.041	665.042	665.043	665.044	○	○	○	5,5-6,6	20,00	28,28	40,00	12,41	48,99	63,25	74,83	89,44
-	-	-	665.084	○	○	○	6,2	25,00	35,36	50,00	15,50	61,24	79,06	93,54	111,80
665.121	665.122	665.123	665.124	○	○	○	7,4-8,3	31,50	44,55	63,00	19,56	77,16	99,61	117,86	140,87
-	665.202	-	-	○	○	○	10,5	50,00	70,71	100,00	31,04	127,47	158,11	187,08	223,61

E = Narrowest free cross section. * US gal/min.

Subject to technical modifications.

Accessories

Nipple, **066.410.17** (1.4571)
Weight: 65 g

Retaining nut, **065.600.16** (1.4305)
065.600.17 (1.4571)
065.600.30 (Brass)
Weight brass: 60 g

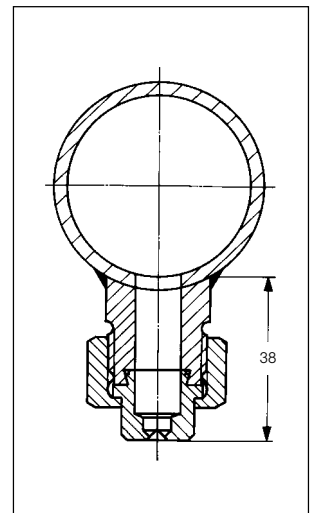
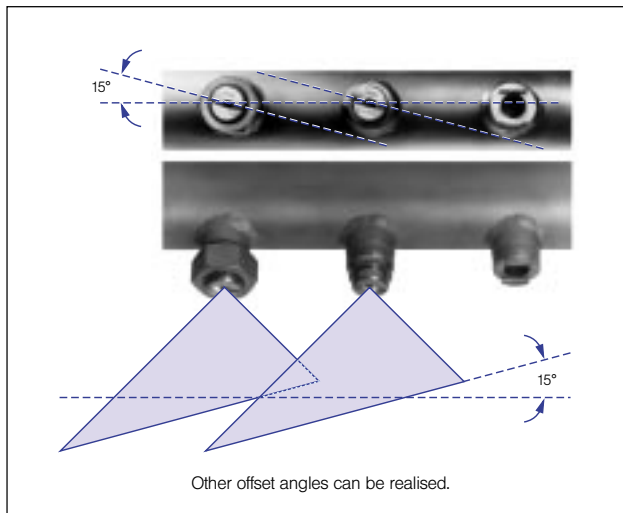

Flat Fan Dovetail Nozzles Series 669

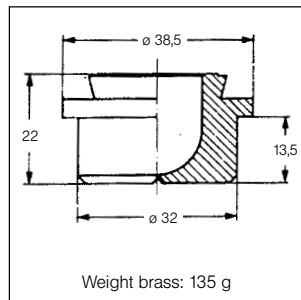

Spray width [B] at p=3 bar

	H 250 mm	H 500 mm
669.041 - 669.281	115	210
669.042 - 669.282	160	310
669.043 - 669.283	250	490
669.044 - 669.284	340	640



Ordering no.				Mat. no.	E Ø [mm]	V̇ [l/min]								
Type						16 303 SS	30 Brass	p [bar]						
20°	30°	45°	60°			0,5	1,0	2,0	40* psi		3,0	5,0	7,0	10,0
669.041	669.042	669.043	669.044	○	○	5,5-6,5	20,00	28,28	40,00	12,41	48,99	63,25	74,83	89,44
669.121	669.122	669.123	669.124	○	○	7,3-8,3	31,50	44,55	63,00	15,50	77,16	99,61	117,86	140,87
669.201	669.202	669.203	669.204	○	○	9,5-10,6	50,00	71,00	100,00	31,00	122,00	158,00	187,00	224,00
669.281	669.282	669.283	669.284	○	○	9,4-13	80,00	113,00	160,00	49,60	196,00	253,00	299,00	358,00

E = Narrowest free cross section. * US gal/min.

Subject to technical modifications.

Accessories

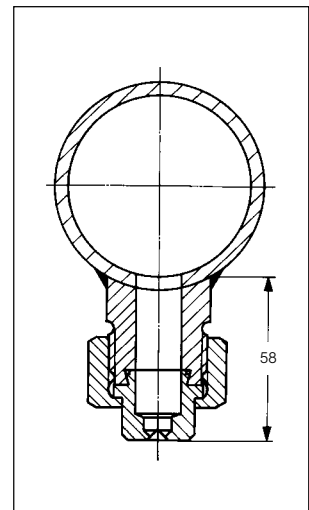
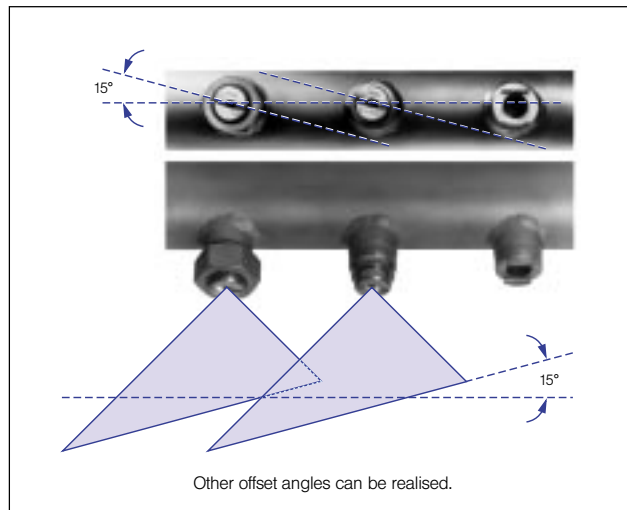
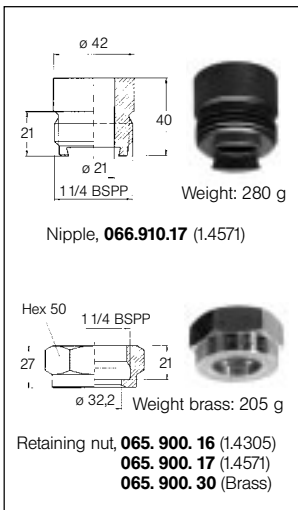

Lechler – Your Proficient Partner for Roll Cooling Systems

Today's steel producers have to operate in a tougher environment than ever before, caused by:

- Customer requirement for improved quality
- Constant pressure on costs
- Fluctuating demand
- Tighter pollution controls

Pioneers in harnessing spray technology to steel production

Nozzles and spray systems are used in virtually every stage of steel production and their performance can have a major impact on product quality and manufacturing costs. For over 120 years, Lechler has pioneered developments in spray technology for all stages of primary metals production, designing, developing and manufacturing products of outstanding reliability and performance. All accompanied by expert advice based on a thorough knowledge of the industry, providing both conventional and innovative solutions. Today, Lechler offers the most comprehensive range of nozzles and spray systems for iron, steel and non-ferrous metals producers. From secondary cooling for continuous casting to shape control in cold rolling mills and descaling, Lechler has a proven solution.

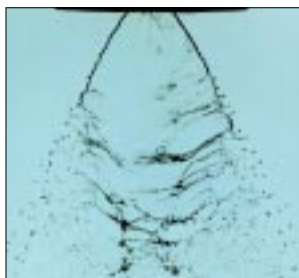

Serving steel producers worldwide

Lechler is a truly international company, offering sales and technical support to the metals industry worldwide. In addition to over 400 employees at our Metzingen headquarters in Germany, subsidiary companies have plants and offices in the USA, the UK, India, France, Belgium, Sweden and Hungary. We also have a network of sales offices and representation covering many other countries.

Wherever you are, Lechler seeks to establish a partnership, assisting you to enhance product quality through the application of advanced fluids engineering expertise.



Flatness Control in Rolling Mills

The key to a quality product is ensuring control of the roll profile and maintaining the critical thermal profile of the product and back up rolls. The

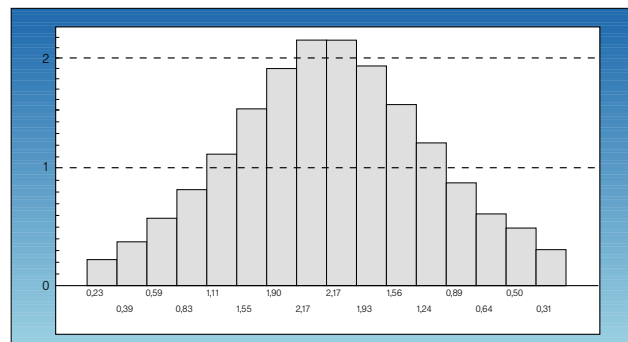

Example for liquid distribution measurement.

optimal nozzle arrangement applies coolant precisely to maximise heat removal and lubricate the roll bite. This extends roll life and ensures a flatter product, with consistent surface characteristics.

Using our expertise and specially developed software, Lechler will evaluate your present roll cooling installation and present an analysis of its performance. The next stage comprises recommendations for header configurations which will improve the efficiency of your roll cooling.

Every Lechler system is bespoke designed for each individual rolling mill to ensure effective cooling.

Our nozzles or header systems can be combined with descaling headers to provide improvements in operational efficiency and product quality.

Flat Fan Dovetail Nozzles

Lechler flat fan dovetail nozzles are the ultimate choice for fast precise header set-up and ease of maintenance. These nozzles offer consistency of spray parameters with the advantage of self alignment, ensuring spray characteristics are unaltered by nozzle

replacement or maintenance. They have a parabolic liquid pattern, ensuring a high heat transfer coefficient and uniform coolant distribution.

Within the standard dovetail range is a wide choice of flow rates and spray angles, ensuring there will be the optimum Lechler nozzle for your application.



Advantages of Lechler Flat Fan Dovetail Nozzles

- Easy assembly
- Self alignment
- Extremely uniform liquid distribution across the header
- High Heat Transfer Coefficient
- Wide choice of standard flows and spray angles for most applications



Special Products



Lechler GmbH + Co KG
 Precision Nozzles · Nozzle Systems
 P.O. Box 13 23
 D -72544 Metzingen / Germany
 Phone: ++49 (0) 71 23 962-0
 Fax: ++49 (0) 71 23 962-333

E-mail: info@lechler.de
 Internet: <http://www.lechler.de>

Series 672 with Socket Alignment System

The Socket Alignment System has already been used for SCALEMASTER® high pressure descaling nozzles. Now this proven approach is available on low pressure flat fan nozzles, series 672. Please ask for more information



Please ask for more information on the following topics:

High pressure Nozzle System SCALEMASTER® for hydromechanical descaling, work-roll cleaning and inter-stand strip cooling

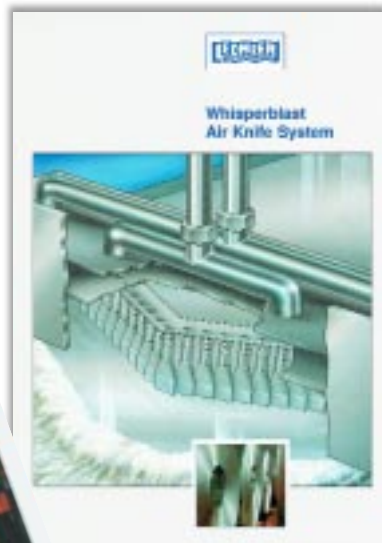

Whisperblast Air Knife System for strip wiping and drying

Selective Roll Cooling System SELECTOSPRAY® for cold rolling mills, foil mills etc.



Lechler Ltd.
 1 Fell Street, Newhall
 Sheffield, S9 2TP
 Great Britain
 Phone: (01 14) 2 49 20 20
 Fax: (01 14) 2 49 36 00
 E-mail: info@lechler.com

Lechler France, S.A.
 Immeuble CAP2 C51
 66, Rue Marceau
 93558 Montreuil, France
 Phone: (1) 49 88 26 00
 Fax: (1) 49 88 26 09
 E-mail: info@lechler.fr

Lechler R.E.I. S.A.
 Avenue Galilée, 6
 Parc Industriel Nord
 1300 Wavre, Belgium
 Phone: (10) 22 50 22
 Fax: (10) 24 39 01
 E-mail: reilec@skynet.be

Lechler AB
 Box 8080
 16308 Spanga
 Sweden
 Phone: (8) 7 61 00 80
 Fax: (8) 7 61 00 84
 E-mail: info@lechler.se

Lechler Inc.
 445 Kautz Road
 St. Charles, IL 60174
 USA
 Phone: (630) 3 77 66 11
 Fax: (630) 3 77 66 57
 E-mail: metals@lechlerUSA.com

Lechler (India) Pvt. Ltd.
 Plot # A-109, Road # 18
 Wagle Industrial Estate
 Thane-400 604, India
 Phone: (22) 5 32 11 96
 Fax: (22) 5 32 12 62
 E-mail: lechler@bom3.vsnl.net.in